

Vibration Table Interfaces:

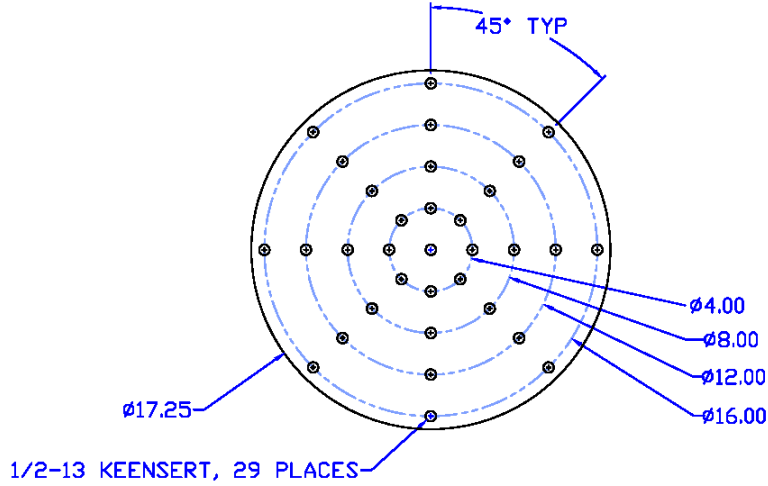

Shaker Head (Vertical)

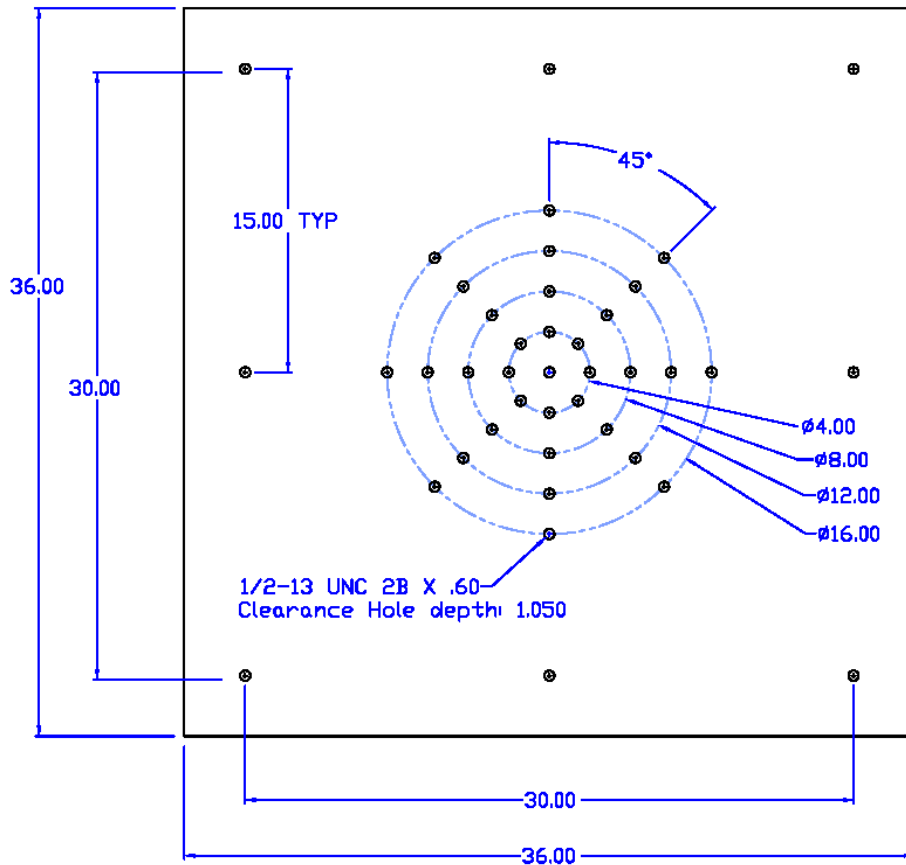

Slip Table (Horizontal)

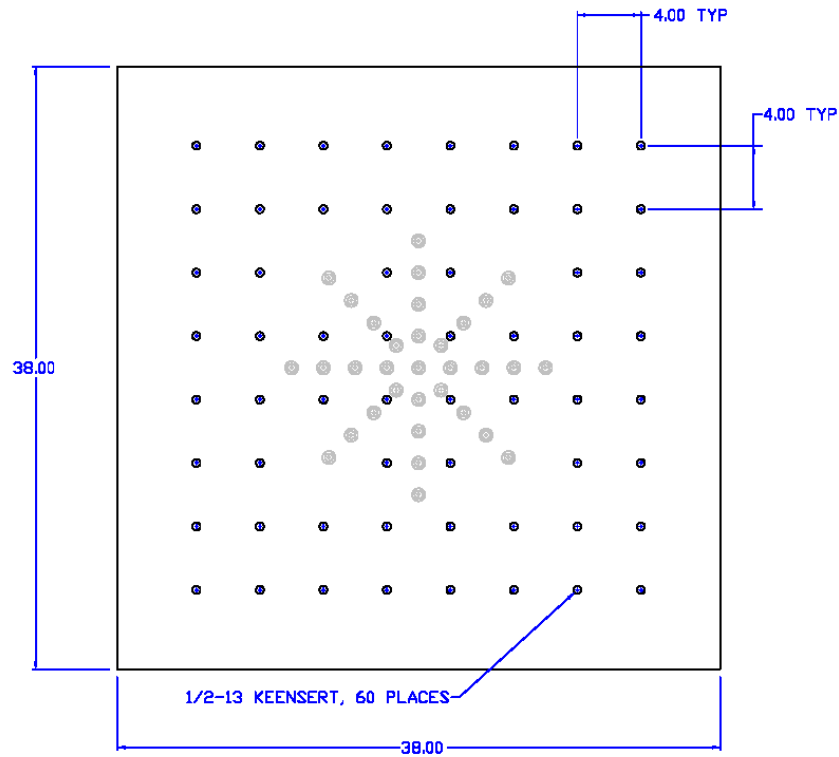

Head Expander (Vertical)

(Provides increased mounting surface and locations)

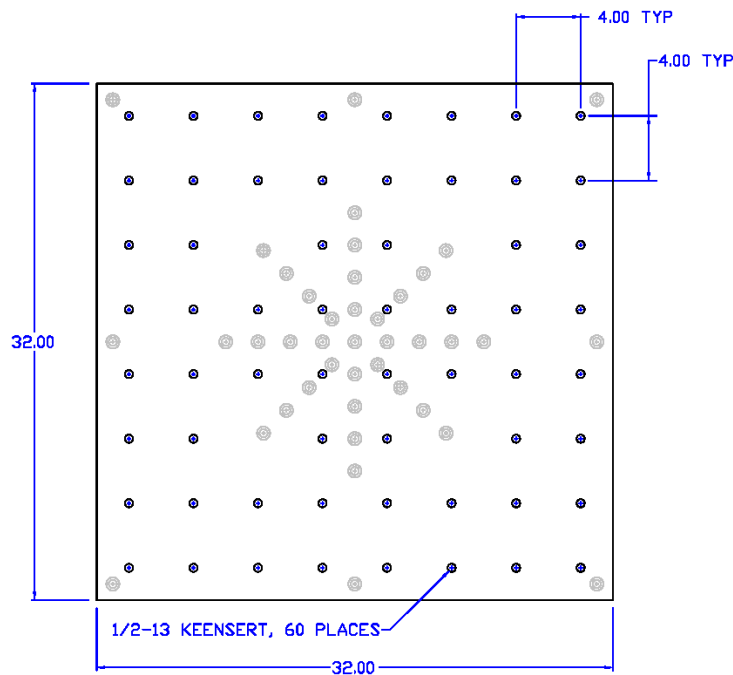

Slip Table Adapter (Horizontal)

(Provides increased mounting locations)

3-axis Cube and Adapter Plate
Reduces set-up and handling for small parts

